

FRONT VIEW

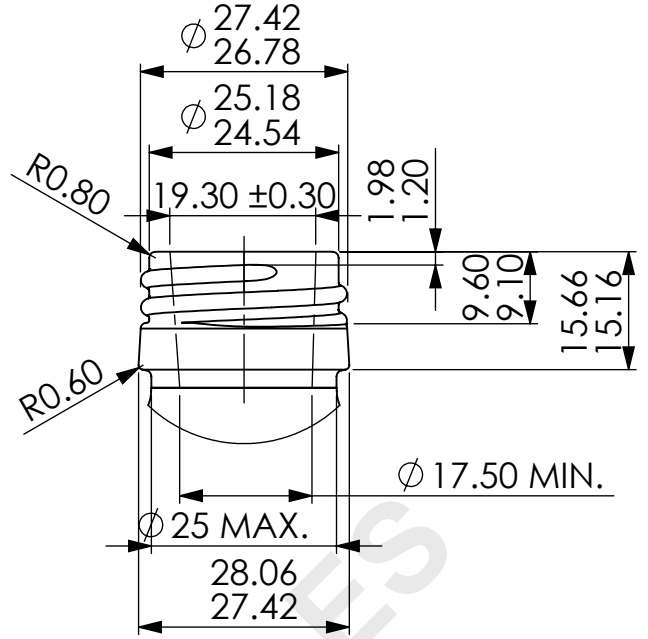

DETAIL A  
SCALE 1 : 1

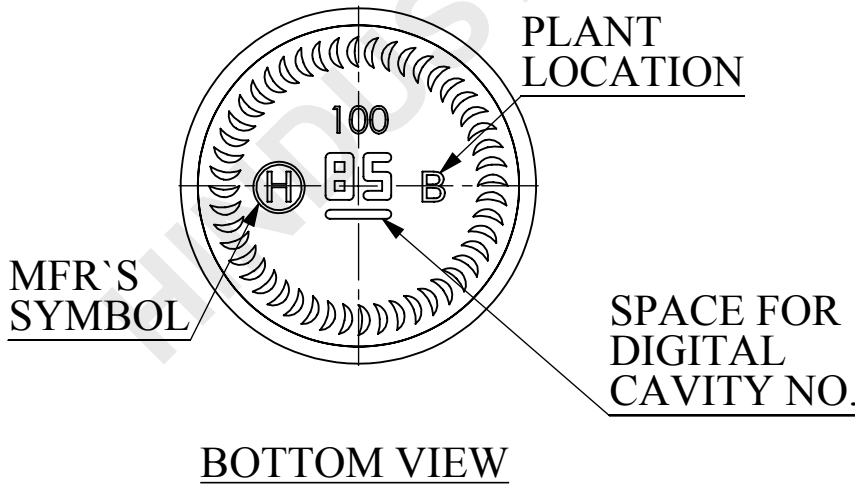

BOTTOM VIEW



ALL DIMENSIONS ARE IN MILLIMETERS

<b>PROCESS</b> B&B						SPECIFICATION AGREEMENT ARE BASED ON TOLERANCED DIMENSIONS ONLY DO NOT SCALE DRAWING COPYRIGHT RESERVED. NOT TO BE COPIED IN WHOLE OR PART WITHOUT WRITTEN PERMISSION FROM H.N.G.& I. LTD.		
MINIMUM THROUGH BORE	-							HINDUSTHAN NATIONAL GLASS & IND. LTD.
FILL POINT VERIFIED	-							TITLE 100 ML AMBER ROUND 28PP SYRUP BOTTLE CUST GENERAL MARKET
TILT ANGLE	21.50°	No.	REV.No.	REVISION	DATE	CHK	DRC	DRN Sandeep DR_DT 06/12/2013 CHK. CHK_DT. APPD. APPD_DT.
MAXIMUM DEPTH OF STANDARD ENGRAVING	-	FILL-POINT						
MAX. GAS VOLUMES	-	BRIMFUL CAP.	113 ± 2.5 ML.					
REF DRG No :-	W1-01549	WEIGHT	95 ± 5.0 GMS.					
MOULD EQUIPMENT ORDERED BY		FINISH	28 MM R.S.P.P. STD.		COLOUR	AMBER		
PLANT	B	SURFACE TREATMENT	NO		C.C. NO.	HNG-694		DRAWING No. HNG-00694
								A4 REV